

Biomethane workshop

Anaerobic Digestion of regional food waste - A scenario development

Aidan Cumiskey
Managing Director



MONSAL®

advanced digestion technology

Monsal In summary

- Based in Mansfield
- Formed 1995 privately owned with strategic investor – Matrix Group
- Network of 40 + highly skilled and experienced staff
- Focus on Advanced Digestion as our platform technology
- Fully certified and developed supply chain for all AD components
- Water sector - Largest portfolio of conventional and advanced AD technology in the UK
- Waste sector - Biowaste AD – Now Integrated AD technology offering for organic waste and renewable energy markets

Monsal pre 2007 – lots and lots of digestion technology supplied to water utilities – over 200!



MONSAL®

advanced digestion technology

Advanced Technology – more biogas and power

Anglian Water – Kings Lynn



MONSAL®

advanced digestion technology

Monsal – post 2007

- Strategic expansion in Biowaste
- No time to get into waste organically
- New technology required to bolt on to existing AD platform
- Now turnkey Biowaste AD as result of:
 - Acquisition of technology (Pre-processing)
 - Transfer manufacturing to UK
 - Expand system engineering capability
 - Fully developed UK supply chain
 - Full services & support offering
- Monsal committed to developing our business model in EM
- Now making significant impact on waste market

Anaerobic digestion of Biowaste - Flowsheet

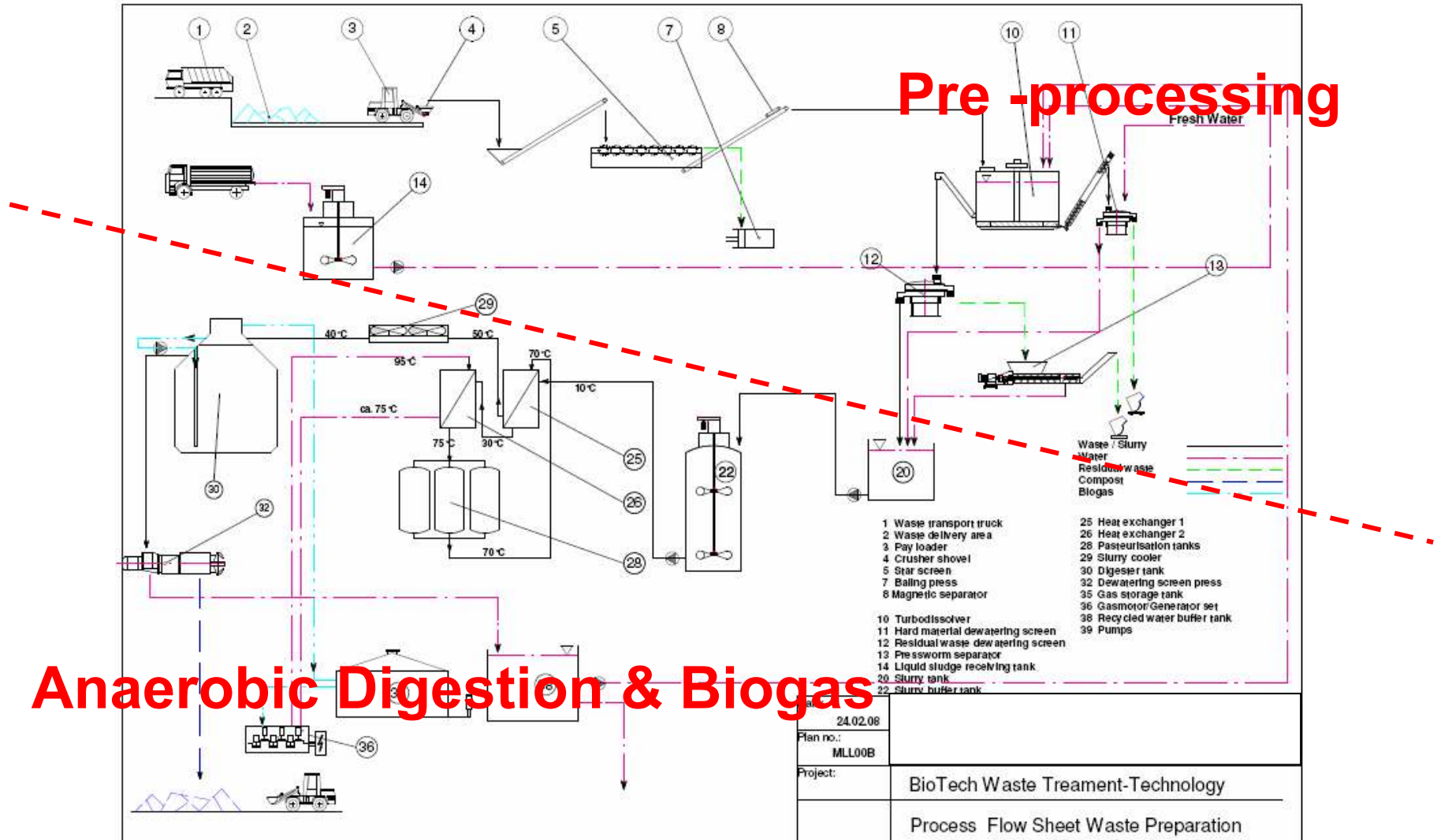

Cleaning up Biowaste – how it works



**Long term track record – 10 year operation
Boden – 30,000- 40,000 Tonne Biowaste plant**

15 operational references to date



Deerdykes - 1st Major Biowaste plant in Scotland

- Scottish Water Waste Services
- IVC operation expanding into renewable energy
- 30,000 Tonnes biowaste
- 1 MWe +, Compost and Heat
- Operational April 2010

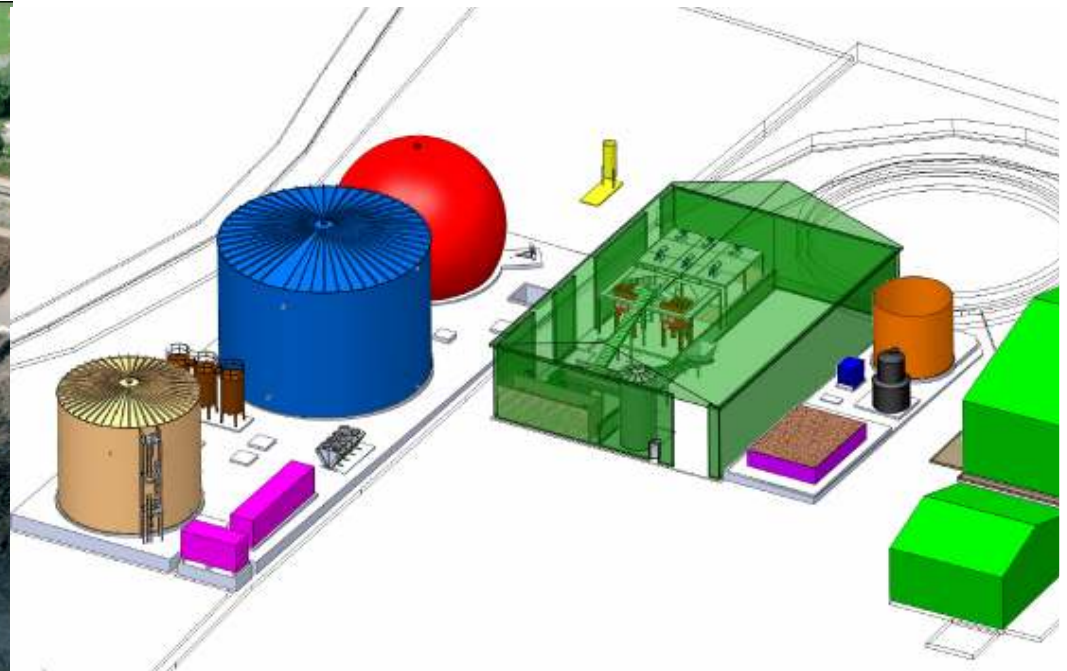

March - 1st Major Biowaste plant in E. Anglia

- Lifecrown Investments– Local Generation subsidiary
- Food processing expansion into renewable energy
- 30,000 up to 60,000 Tonnes food waste
- 3 MWe, Compost and Heat



Biowaste treatment market – our offering

- Biowaste Portfolio
 - Waste dissolver technology
 - Biowaste de-packaging and preparation technology
 - Advanced hydrolysis and pasteurisation technology
 - Digester process equipment
 - Odour control equipment
 - Liquor treatment technology
 - Turnkey plants with integrated CHP

All core equipment manufactured to our specification in the UK with full service support

Scenario 1 – Feedstock information

- Potato Peel/grey starch 58%
- Offal – Chicken 20%
- Pre-packed & mixed sandwiches 11%
- Crisp manufacture 4%
- Eggshell – Chicken 3%
- Feathers – Chicken 3%
- Blood – Chicken 0.5%

Total 40,000 Tonnes/annum

Scenario 1 development – Key points

- Fully integrated AD solution
 - In – Biowaste
 - Out – Fuel (and/or Power/heat) , product, wastewater
- < £10m total infrastructure cost inc. development
- < 10,000 m²
- Utility quality spec. (not Ag)
- Options to expand to SS collections
- ~ 1.5 MWe equivalent - power
- High quality product

Summary

- Monsal are a regional EM business with national impact
- Strong AD credentials and supply chain
- Strong commercial and technical offering for Biowaste AD
- Biowaste AD market now starting to develop nationally
 - Deerdykes/Peterborough ++
- CENEX study demonstrates feasibility of EM based AD facility
- Monsal positioned to provide quality technology platform to midlands scenario

Thank you



MONSAL®

advanced **digestion** technology